

Components Systems Applications

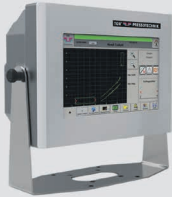

Content

Components

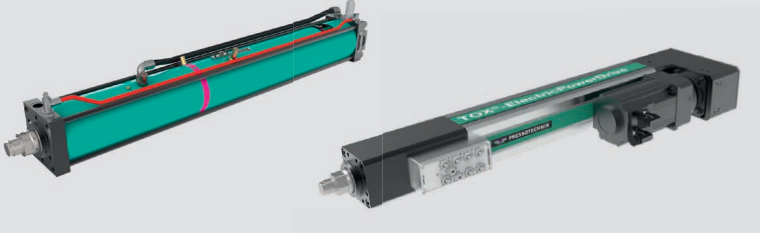

Pages 6 – 11

Systems



Pages 12 – 15

Applications

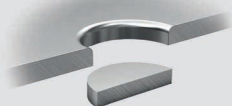
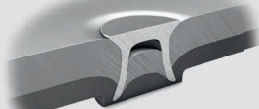
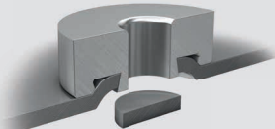
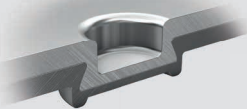

Pages 16 – 23

Worldwide

Worldwide presence, local competence: TOX® PRESSOTECHNIK is represented around the globe in 45 countries with its own production and sales locations. Local subsidiaries with highly qualified employees who are familiar with the regional product requirements provide support to each market and its customers.

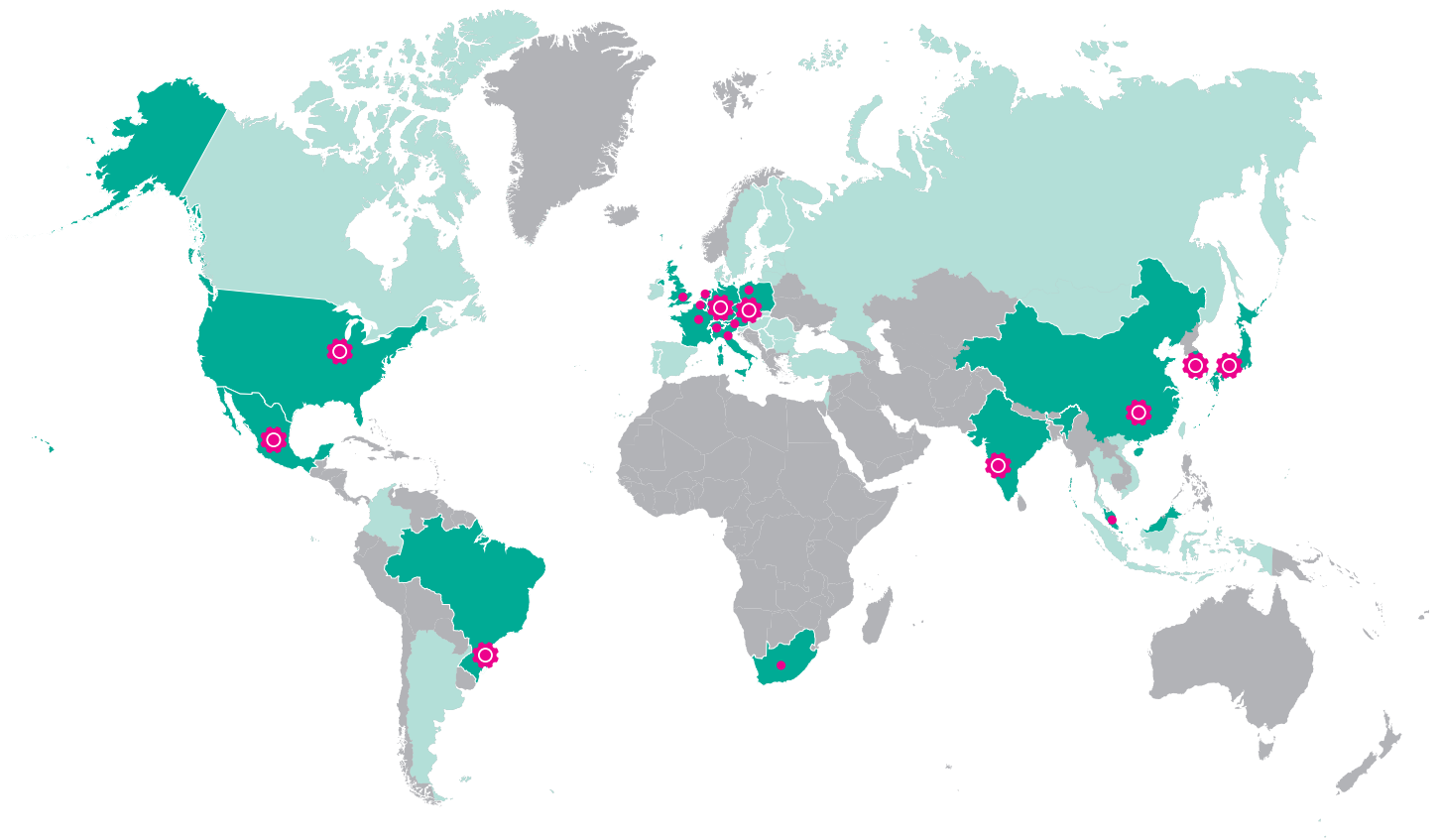

Subsidiaries



Production sites

- Brazil
- China
- Germany
- India
- Japan
- Mexico
- South Korea
- Czech Republic
- USA
- Belgium
- France
- Great Britain
- Italy
- Malaysia
- The Netherlands
- Austria
- Poland
- Switzerland
- South Africa

Representation and sales partners

- Argentina
- Bulgaria
- Denmark
- Estonia
- Finland
- Indonesia
- Ireland
- Israel
- Canada
- Colombia
- Latvia
- Lithuania
- Luxembourg
- Portugal
- Romania
- Russia
- Sweden
- Serbia
- Slovakia
- Slovenia
- Spain
- Taiwan
- Thailand
- Turkey
- Hungary
- Vietnam

Individual Solutions for our Customers

TOX® PRESSOTECHNIK designs process flows more economically – with special systems, intelligent assembly systems and fully automatic feeds with integrated additional functions. We possess long-standing experience and comprehensive know-how in the development and design of these systems.

We look to create highly efficient systems to match our customer's designated work flow. We are committed to finding the best solution for optimizing the manufacturing processes according to our customer's requirements.

For this reason, our machines are the product of close cooperation between our customers and our project managers. Our service team will also be on hand quickly and reliably at all times following delivery.

Identify demand

An extensive consultation forms the basis of each concept for us – for special machines as well as production systems. We use much experience and a high level of expertise to identify the framework conditions, determine the required components, and sketch out a first system layout. In our lab we can perform sampling runs with original materials, components and elements in parallel.

Development process

The specific system concept is forwarded to our design department, which creates the machine layout and generates detailed drawings for production. The components are manufactured or procured according to plan and the system is assembled. Then, the control components are installed and configured.

Commissioning

Once completed, the machine is „test-driven“. When all customer requirements are met, machine validation occurs – customers are encouraged to take part. Following delivery, set-up and connection of the system, on site commissioning is supported by our qualified personnel.

After-sales service

The operating personnel receive extensive training either on our premises or on site using the delivered system. Often, we also support initial production and provide advice and assistance. When everything is running smoothly, all that is required are minimal, routine maintenance tasks.



TOX[®]-Powerpackage

Press force between 2 and 2000 kN

TOX[®] PRESSOTECHNIK knows how to effectively combine the benefits of compressed air and oil. The result is the TOX[®]-Powerpackage series – powerful pneumohydraulic drive cylinders, providing a press force between 2 and 2000 kN. The functional design with few moving parts reduces wear and increases the service life. The low impact forces of the fast approach stroke protect the tool and reduce the noise level. A mechanical spring with dual function ensures low energy consumption. The low air consumption in the unit allows for high speeds with the smallest valve cross-sections.

Advantages

- Few moving parts
- Low energy consumption
- High wear resistance
- High stroke frequency
- Long service life

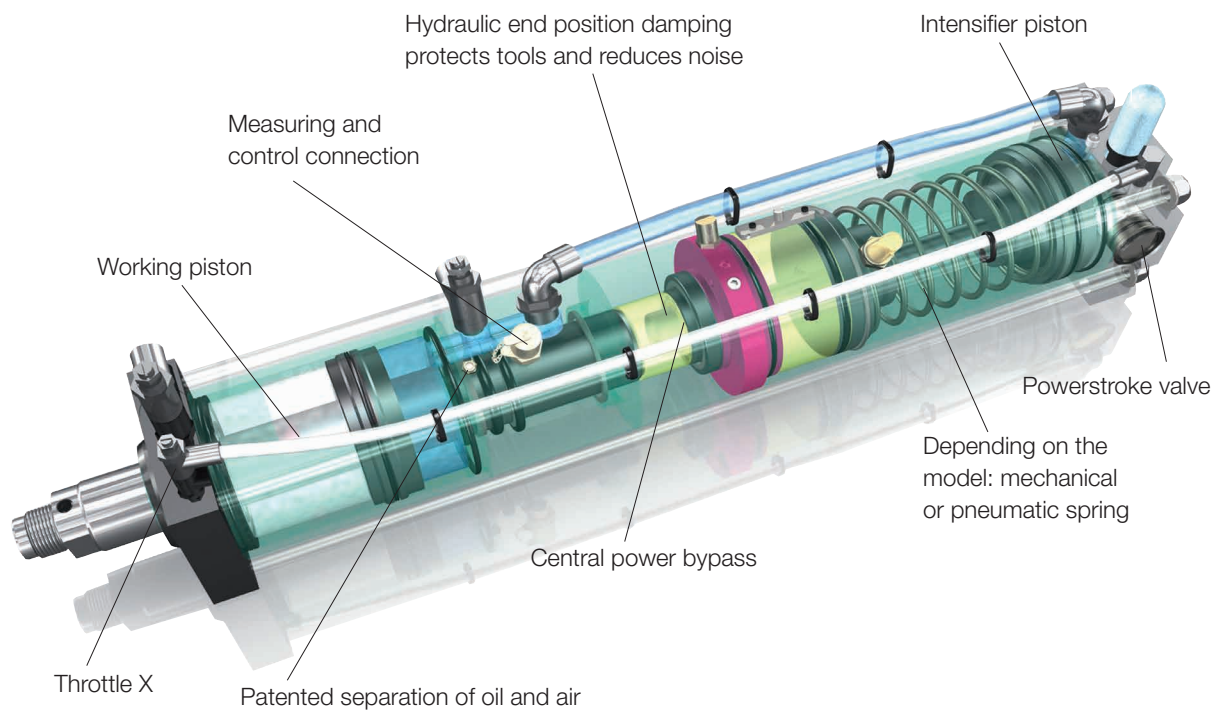

The pneumohydraulic drive family

The line-Q series

- Available in common standard sizes
- Shortest delivery times
- Attractive price
- Mechanical return spring

Press forces: 2–300 kN
 Total stroke: up to 200 mm
 Powerstroke: up to 52 mm
 Compressed air: 2 – 6 bar

Design S (standard)



Type Q-S

Design K (compact)

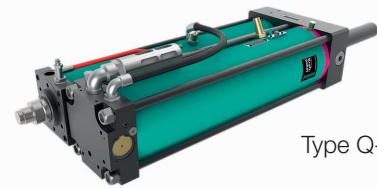

Type Q-K

The line-X series

- Most configurable
- Can be configured according to the applications
- Precisely controllable and adjustable
- High stroke speeds
- Pneumatic spring

Press forces: 2–1700 kN
 Total stroke: up to 400 mm
 Powerstroke: up to 69 mm
 Compressed air: 2 – 6 bar



Type X-S

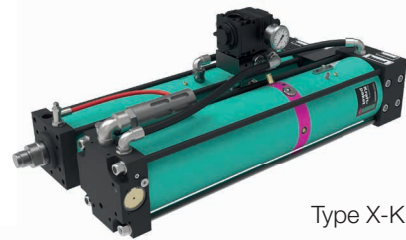

Type X-K

Special types

- Application-specific design
- Complete range of types
- Compatible with the whole range of accessories
- Mechanical spring or air spring (depending on the version)

Press forces: 2–1740 kN
 Total stroke: up to 400 mm
 Powerstroke: up to 80 mm
 Compressed air: 2 – 10 bar

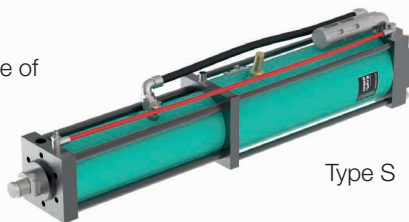

Type S

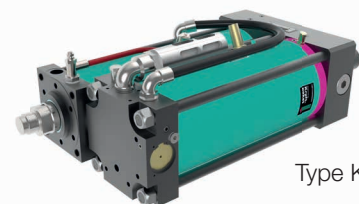

Type K

X-KT system

- With separate intensifier for one or several working cylinders
- For long powerstrokes
- Working cylinders can be activated individually
- Compact size, flexible mounting

Press forces: 2–2000 kN
 Total stroke: up to 400 mm
 Powerstroke: up to 100 mm
 Compressed air: 2 – 10 bar

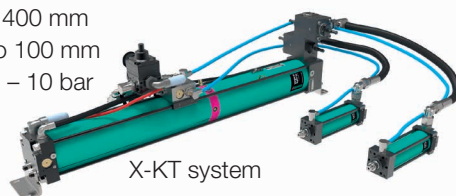

X-KT system

The series RP (marking cylinder), T (turbo cylinder) and RZ (robot tong cylinder)

Press forces: 2–160 kN
 Total stroke: up to 200 mm
 Powerstroke: up to 12 mm
 Compressed air: 2 – 10 bar

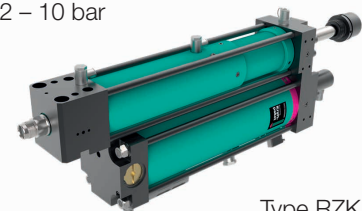

Type RZK

TOX[®]-ElectricDrive Core

NEW!

Electromechanical drive technology smart and intelligent

The TOX[®]-ElectricDrive Core with its electrical drives can be used in a wide range of applications: from 0.02 kN to 1000 kN. The highly flexible integration into existing control environments saves time and costs – drive control, process monitoring and quality assurance are combined in one system.

The intuitive HMI meets all your requirements: it impresses with customizable user interface as well as clear, freely definable dashboards. It runs on the customers PC or on our TOX[®]-UDI panels.

Advantages

- Fast commissioning due to the intuitive operation of the software: Plug-and-Play
- Cost saving due to slim control architecture
- Seamless quality assurance
- Predictive Maintenance ready
- Quality data and evaluation in one system

TOX[®]-ElectricDrive Core the new system



TOX[®]-SoftWare

- Visualization HMI
- Storage of the quality data or forwarding to server
- operating system independent (Windows / Linux)
- on customer PC, line PC or TOX[®]-UDI Panel

TOX[®]-ElectricPowerDrive

The powerful drives



TOX[®]-EdgeUnit

The decentralized intelligence for every drive



TOX[®]-PowerModule Core

- Servo inverter with application for force-travel control included
- Main interface and connection to the fieldbus system
- All functions of your application are pre-parameterized

The electromechanical drive family

EQe

TOX®-ElectricPowerDrive EQe-K

- Press force range 0.02 kN – 100 kN
- Available in types
22 kN/5 kN/10 kN/30 kN/60 kN/100 kN
- Total stroke 150/300/450 mm
- Speed up to 300 mm/s



EXe

TOX®-ElectricPowerDrive EXe-K

- Press force range 0.1 kN – 200 kN
- Available in types
10 kN/30 kN/60 kN/100 kN/200 kN
- Total stroke 150/300/450 mm
- Speed up to 300 mm/s



TOX®-ElectricPowerDrive EXe-F

- Press force range 0.05 – 100 kN
- Available in types
5 kN/10 kN/30 kN/60 kN/100 kN
- Total stroke 150/300 mm
- Speed up to 800 mm/s
- Increased service life
- High acceleration



TOX®-ElectricPowerDrive EXe-L

- Press force range 3 kN – 1000 kN
- Available in types
300 kN/400 kN/500 kN/700 kN/1000 kN
- Total stroke 300 mm
- Speed up to 90 mm/s



TOX[®]-Controls

Safe and reliable controls are indispensable for operators. TOX[®]-Controls stand for safe process control – either with the pneumatic basic version, the electropneumatic version or a programmable logic controller. All controls from TOX[®] PRESSOTECHNIK are based on a flexible modular principle. They are simple to operate and correspond to the new Machine Directive MRL 2006/42/ec. Implementation of the functional safety from the design phase to validation of a machine is ensured (e.g. PLe according to DIN EN ISO 13849-1, DIN EN ISO 13849-2).

Advantages

- Well thought out control concepts
- Flexible, modular design
- Simple operation
- Up to PLe according to DIN EN ISO 13849-1, DIN EN ISO 13849-2



TOX®-Monitoring

The process at a glance

Production processes are getting ever more complex as demands on quality are rising. Monitoring systems ensure reproducible precision. They monitor the work processes, represent them in a user-friendly way, reliably store data and provide this data for later tracking. Reliable monitoring is indispensable for the production of a large number of high-quality products. TOX®-Monitoring stands for seamless oversight of force processes. Integrated into common bus systems, our systems provide important information about the process. Our TOX®softWare connects control, monitoring and analysis.

Advantages

- Force-displacement monitoring
- Freely definable windows
- Teachable envelopes
- Process control
- Versatile application and connection options

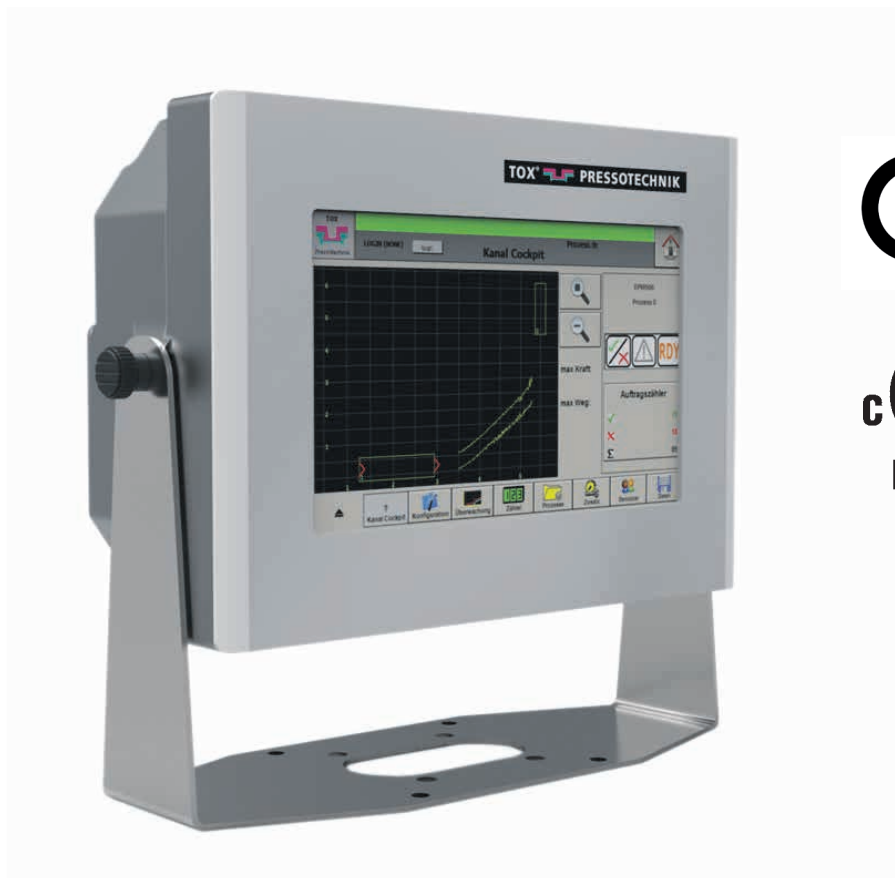

TOX[®]-Tongs

Tong systems for integrated production

Clinching, riveting, punching, press fitting, marking – the TOX[®] PRESSOTECHNIK modular tong system provides an individual solution for each of these applications. Depending on requirements, frames, tools and drives can be combined with controls and monitoring to form a complete solution. The standard interfaces of our components ensure the high quality of our systems.

In addition to the process, the part handling style decides whether robot, machine or handheld tongs are used. The handheld tongs with their compact dimensions are perfectly suited to all areas of sheet metal joining technology.



Advantages

- Flexible, modular design
- Consistently proven concept
- Adaptable to suit customer requirements
- Solutions for a wide range of technologies

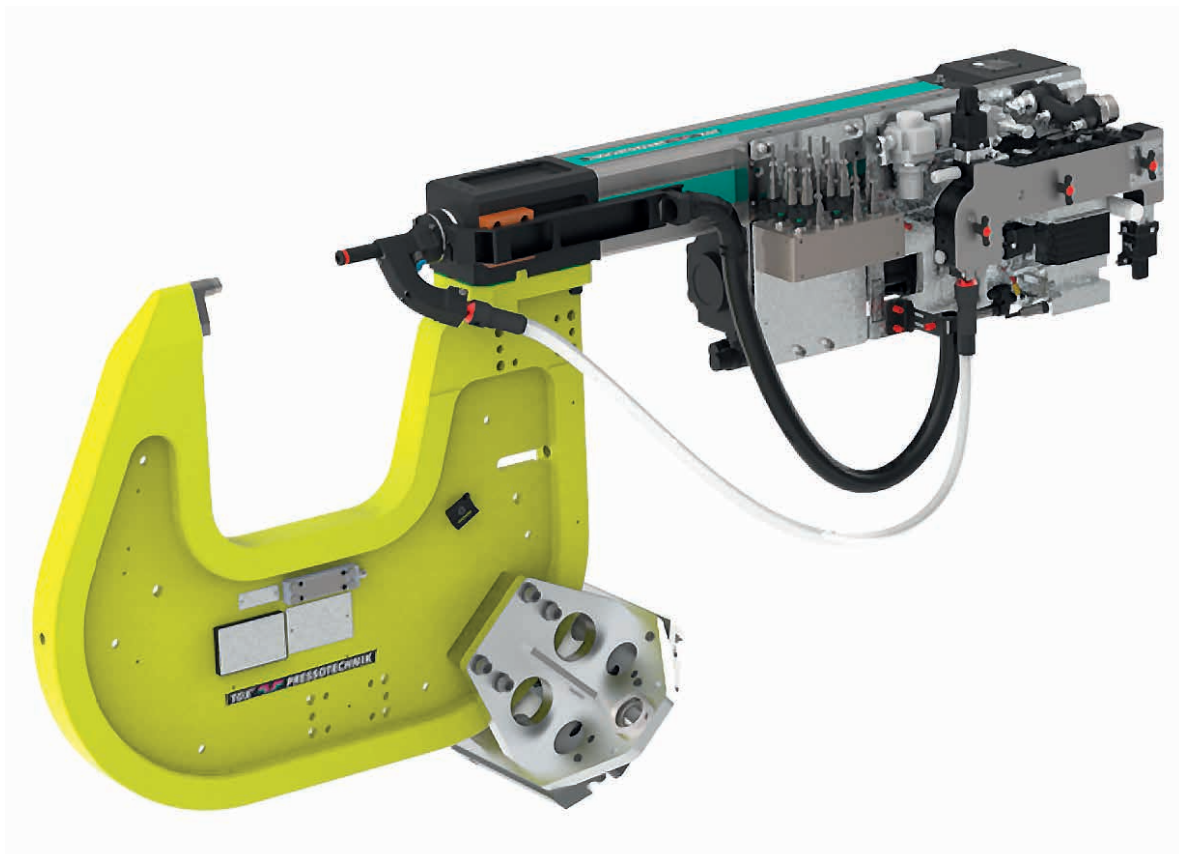

Innovative tong systems

In automated production environments, tong systems must be perfectly integrated.

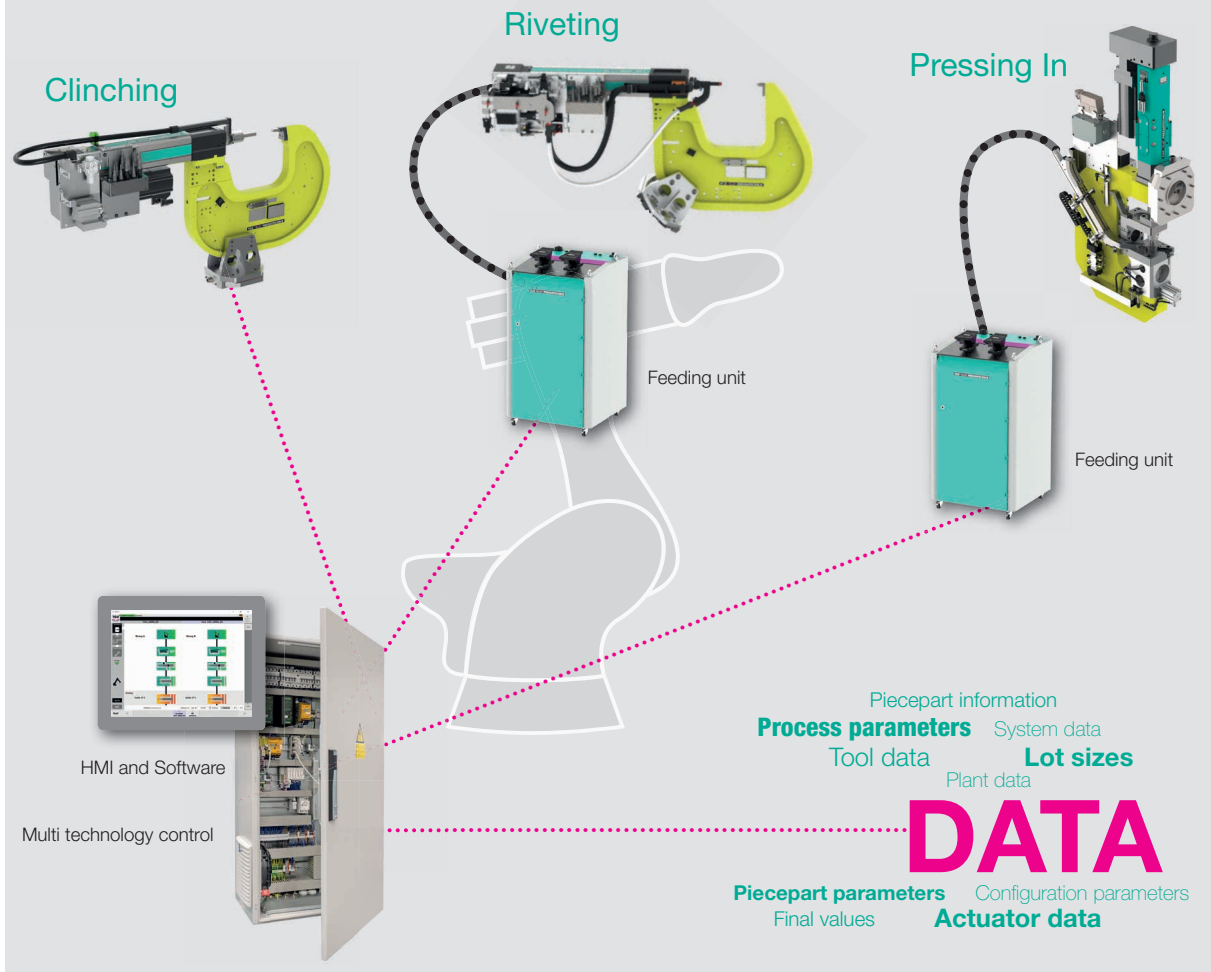

TOX®-PowerKurver

with linear force in the powerstroke range due to its customized curve geometry

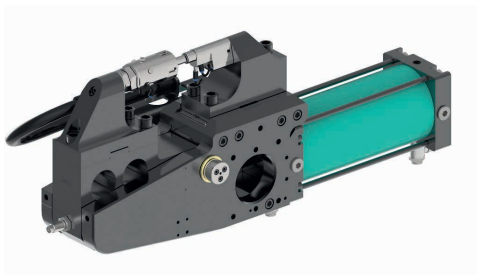

TOX®-Handheld Tongs

with hydraulic drive and external pressure intensifier



TOX®-Mini Tongs

ideal for clinching applications in compact format



TOX[®]-Presses

From single frames to complete presses

From standardized, modular to individual presses – TOX[®] PRESSOTECHNIK is able to fulfill almost every requirement. Thanks to our many years of experience, our modular system and high quality standards, we develop customer-specific systems for a wide range of applications. All components are matched to each other and are completed with control system, protective housing, dies and process monitoring to form a ready-to-operate press with type approval. We also supply only our components on request.

We are also technology experts and can develop solutions for a wide range of manufacturing technologies and applications.

Advantages

- Press force 2 - 2000 kN
- Flexible, modular design
- Customized complete solutions
- Components available separately
- Conformity to local standards
- Simple integration of tools
- All from a single source



The new FlexPress Compact

The compact manual workstation for assembling and manufacturing in series production.

- Available with TOX[®]-ElectricPowerDrive in four versions: 5 kN, 10 kN, 30 kN and 60 kN
- Seamless process and quality monitoring by the new TOX[®]-Software on the 13" touch panel
- Whether clinching, riveting, press-fitting or similar - all technologies covered by TOX[®] can be realized
- Safety for your processes and employees due to illuminated work area
- Little space requirement in your plant hall due to particularly compact stand area

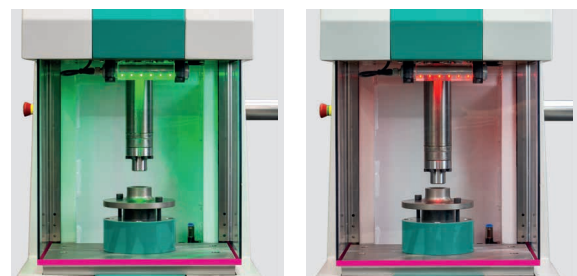

TOX®-FinePress

The family of flexible benchtop presses: Precise, smooth operation and with a robust design those manual presses offer the best price-performance ratio. They can be equipped with various accessories.



TOX®-FlexPress Compact

New: The compact manual workstation with electric drive and pressing forces from 5 kN to 60 kN.

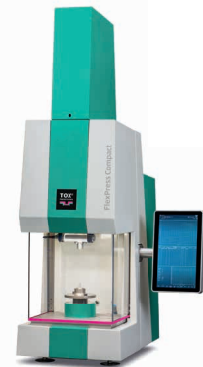

TOX®-C-Frame and C-Bow Presses



Type CEU



Type CEC



Type PC

TOX®-Column Presses

Design with 2 or 4 columns, can be realized with flexible frame openings and widths.



TOX®-C-Frame-Benchtop presses

with linear tool guidance in standard or special dimensions.



TOX[®]-Clinching-Technology

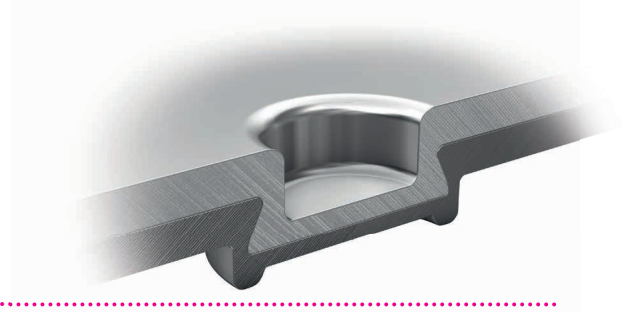

TOX[®]-Clinching describes a simple, robust joining process which works without additional elements or heat – like riveting without a rivet. The positive-locking clinching point is produced when a punch presses the sheets into a specially contoured die. The economical and reliable cold forming process is used throughout the sheet metal processing industry.

Advantages

- Up to 60 percent more cost effective than spot welding
- Allows point sizes from 2 to 26 mm
- High dynamic strength
- Resistant against corrosion
- Electrically conductive
- Joins dissimilar materials
- Can be automatically monitored and documented



TOX[®]-Clinching Tools
(punch and die)

Creation of a TOX[®]-Clinching Joint

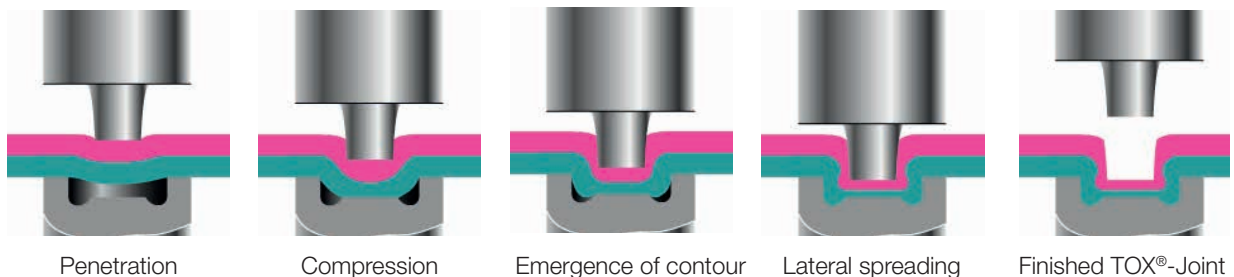

TOX®-Clinching joins ...

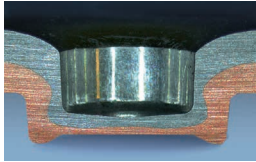

Dissimilar materials

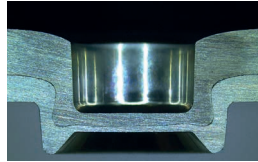

Dissimilar thicknesses

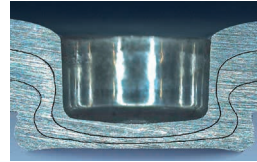

Several layers



Different surface finishes

The right point shape for each application

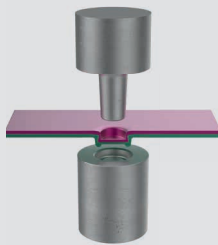

TOX®-Round Joint

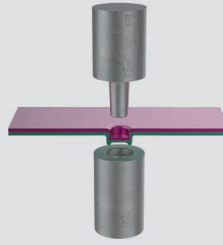

TOX®-MICROpoint

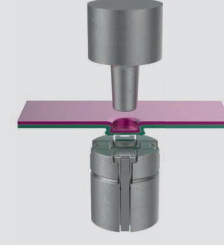

TOX®-SKB

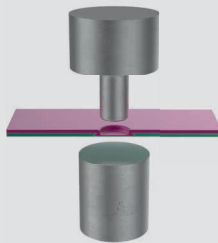

TOX®-Flat-Joint

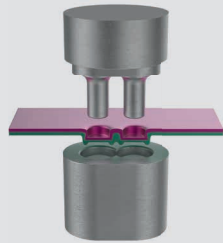

TOX®-TWINpoint

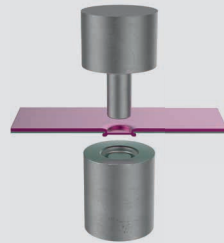

TOX®-Vario-Joint



TOX®-eClinching

Very low contact resistance makes TOX®-eClinching ideally suited for electrical components and is an efficient alternative to solder, welded and screwed connections.

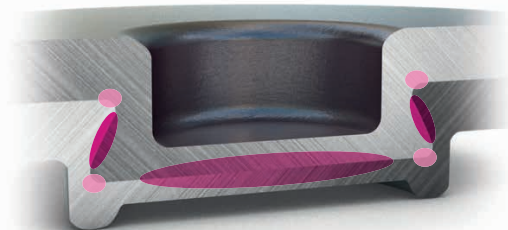
The secret of the good conductivity is the joint zone. During the clinching process, in addition to the positive locking and force locking, there is also an adhesive bond: The joined sheets flow together, resulting in an excellent conductive structure.



Areas with the highest adhesive bond

-  very high (neck area)
-  high (bottom)
-  good

Riveting technology

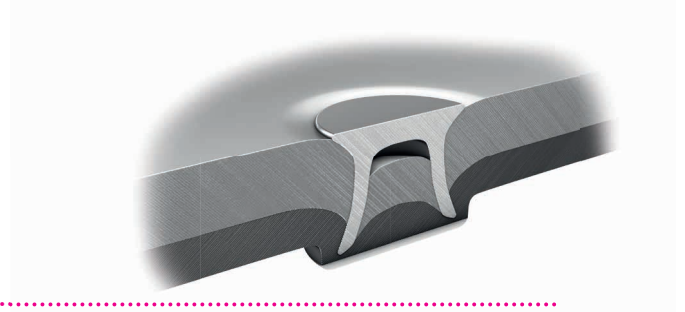

The complete solutions of TOX® PRESSOTECHNIK for riveting comprise competitive feeding and setting technologies, modern controls and systems for process monitoring. Sheet metals are joined application-specifically and reliably with different riveting procedures.

Advantages

- Proven quality through laboratory testing
- Tried and tested feeding technology for all common rivet types
- Standard user interfaces
- Software-based system adjustment (rivet type and manufacturer)
- Systems test and configure themselves independently
- Resistant against impact and electromagnetic fields

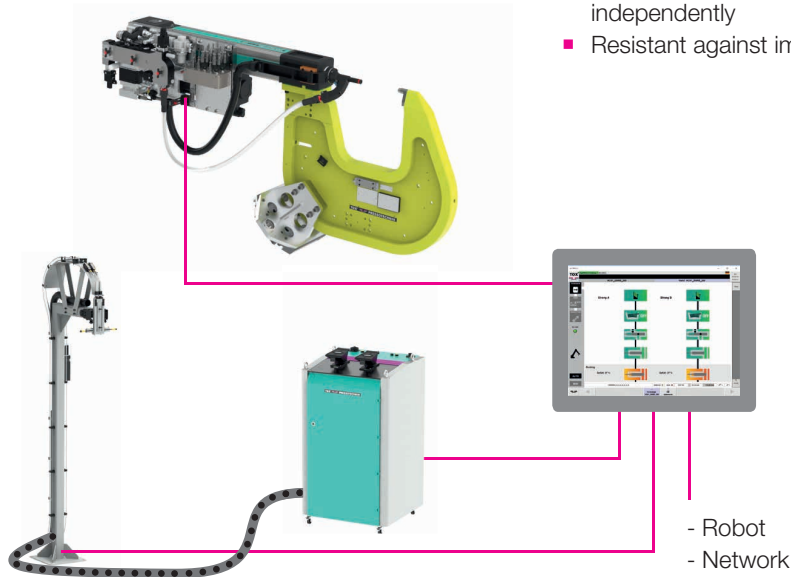

ClinchRivet®

The combination of clinching and riveting: A simple, symmetrical ClinchRivet® is pressed into the sheet layers and forms a high-strength connection without cutting. This procedure is particularly suited to the joining of thin sheets.

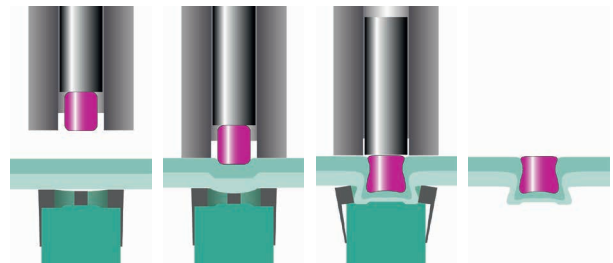

Semi-hollow punch rivet (SPR)

If different materials need to be joined, the semi-hollow punch rivets are ideal joining elements. The first layer is punched, and the rivet creates an undercut in the second layer. Due to their diverse application capability, these rivets are mainly used in automotive lightweight construction.

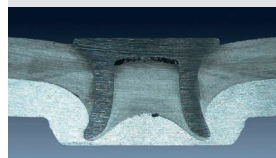
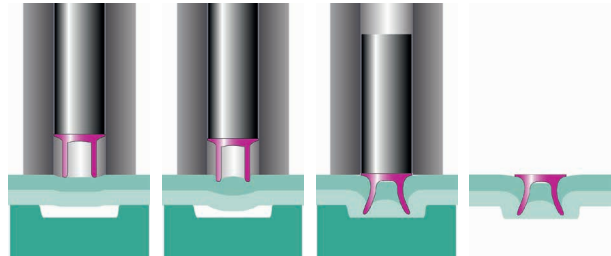

Cross-section of a semi-hollow punch rivet connection.

Solid punch rivet (FPR)

Riveting with solid punch rivets – punching and joining in one step. For a positive-locking connection, the rivet cuts through both sheet layers, then deforms the dieside material for a fatigue resistant joint. This technique is recommended for high-strength connections, brittle material combinations and large variations in thickness.

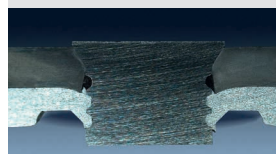
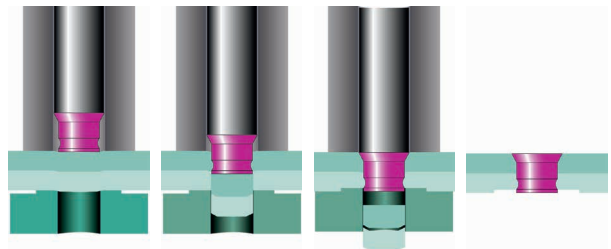

Cross-section of a solid punch rivet connection.

Fastener Insertion Technology

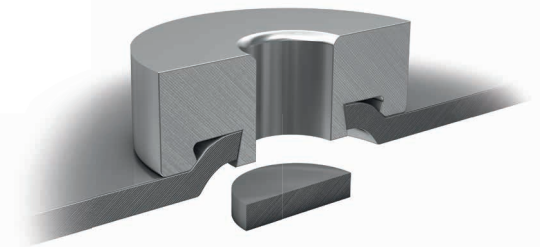

Process competence

Functional elements like nuts, bolts, rivets or screws can be pressed into almost any material. TOX® PRESSOTECHNIK, with its technological solutions, has specialized in the processing of joining and functional elements. Our experts have comprehensive process competence and offer advice and support, from project planning, production of prototypes and validation up to design, manufacturing and assembly as well as commissioning of systems for the insertion of functional elements. This results in quick processes that are easy to reproduce, with energy-saving work processes that impress with high positional accuracy and do not conduct any heat into the component. The product is complemented by training programs and services.

Almost all functional elements are based on four fundamental processing technologies. Clinch elements are shaped such that the component is formed into the element during the pressing process and the element is thus firmly fixed. Self-punching elements are characterized by the component also being pressed into undercuts of the element, after the element punches the required pre-punched hole itself. Press-in elements and rivet elements are inserted in pre-punched and preformed holes where applicable. The rivet is characterized by the element being formed in the process, while the press-in element deforms the component for a strong connection.

Advantages

- Fast processes that are easy to reproduce
- Energy saving
- High positional accuracy
- No additional materials required
- No component distortion caused by heat exposure



System competence

Based on decades of experience, TOX® PRESSOTECHNIK has comprehensive system competence with regard to automatic systems for the processing of functional elements. All process steps – provision, separation, feeding, placing and pressing in – smoothly follow one another and are monitored and analyzed precisely. This achieves consistent quality and repeatable accuracy. The modular TOX®-System enables individual systems that are suitable for numerous functional elements. Our solution is built around the specification of the fastener by our customers.

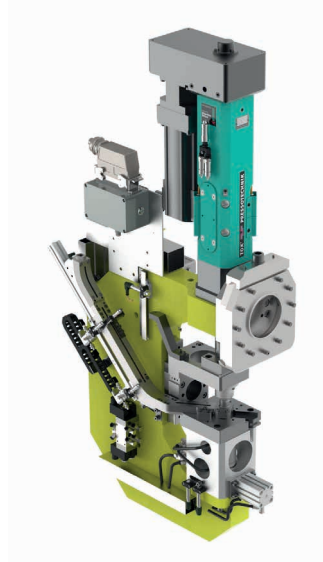

System design

The system design depends on the functional elements as well as the particular application. Systems can be designed as tongs – stationary or mobile – or as a press, depending on requirements. They can be conceptualized as fully automatic, semi-automatic or as pure manual workstations.

Certified quality of all applications by means of test reports

TOX® PRESSOTECHNIK determines the ideal process for the respective application in advance in their own test lab. Preliminary tests are performed and analyzed based on samples. The results deliver important parameters, like the required press force and tool geometry, which contribute to the system configuration and processing technology. Final test reports guarantee the quality of the connection.



Punching and coining systems

Sheet metal, plastic, cardboard, textiles or film – the modular system from TOX® PRESSOTECHNIK provides complete solutions for almost every punching and coining application.

Usually, a TOX® PRESSOTECHNIK drive is mounted to a press frame, and equipped with a tool coupling. Special attention is placed on the damping of the punching impact, to be able to achieve a high service life. Dies, punches and strippers are designed as an assembly, which is moved to the component via guides and guiding carriages. A secured disposal of the slugs completes the setup of the punching system.

Punch contours are adjusted to the individual requirements – from round holes and contours to notches. We can equip the system with punch and slug monitoring on request.

Advantages

- Modular system solution from one source
- Robust and durable drive technology from TOX® PRESSOTECHNIK
- Comprehensive technology protection

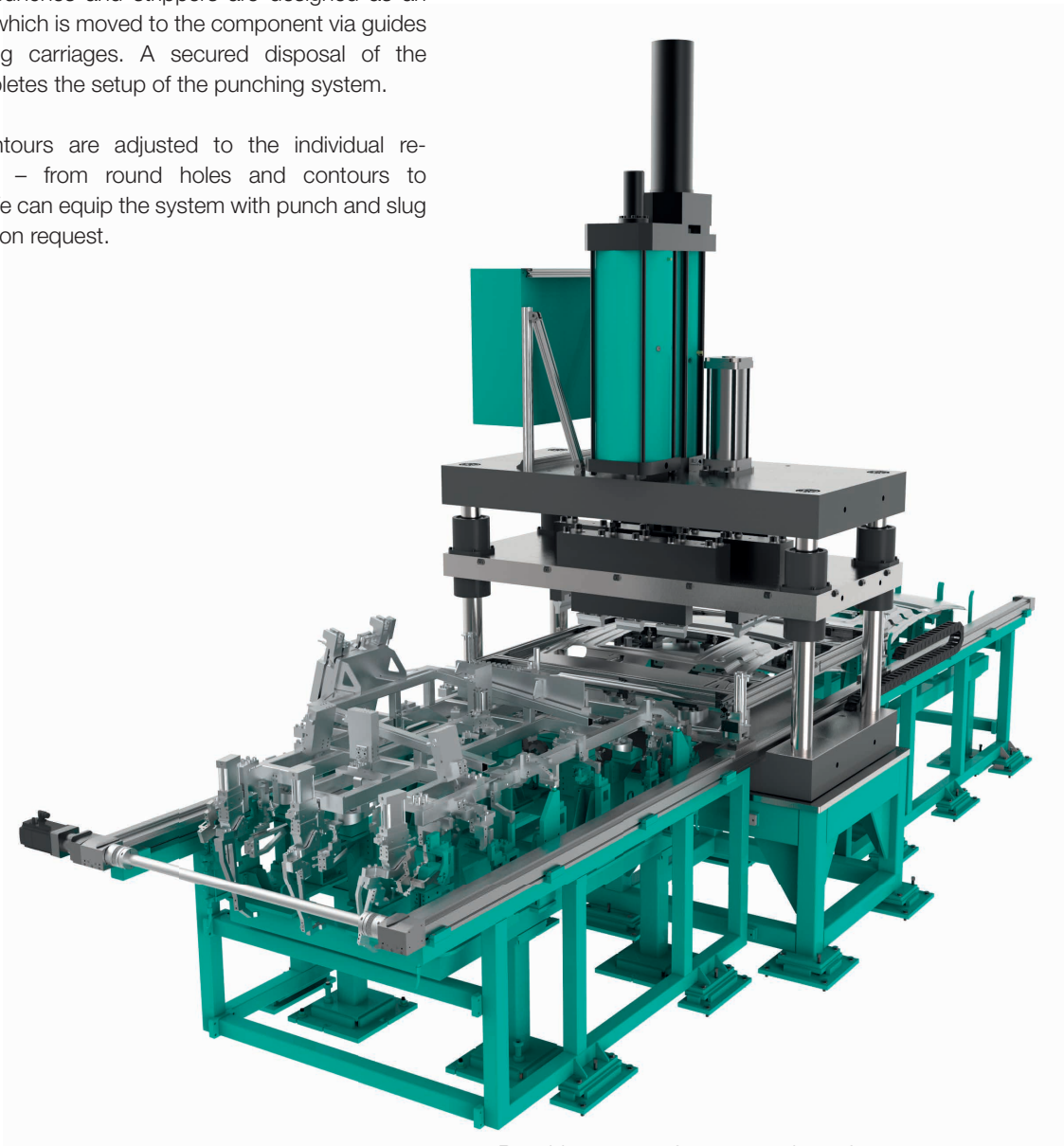

Punching system for panoramic roof with integrated transfer device

Assembly / Press-in systems

The pressing in and on of bushings and bearings or the production of press-fits are complex processes, which require high precision and repeatable accuracy. TOX® PRESSOTECHNIK offers customized solutions, which are delivered ready to use from process analysis and design, to mechanical engineering and software development to integration into existing production systems.

Advantages

- Pressing in and on measuring force and displacement
- Excellent repeat accuracy
- Well thought-out process and quality monitoring



Press-in machine for turbocharger housings

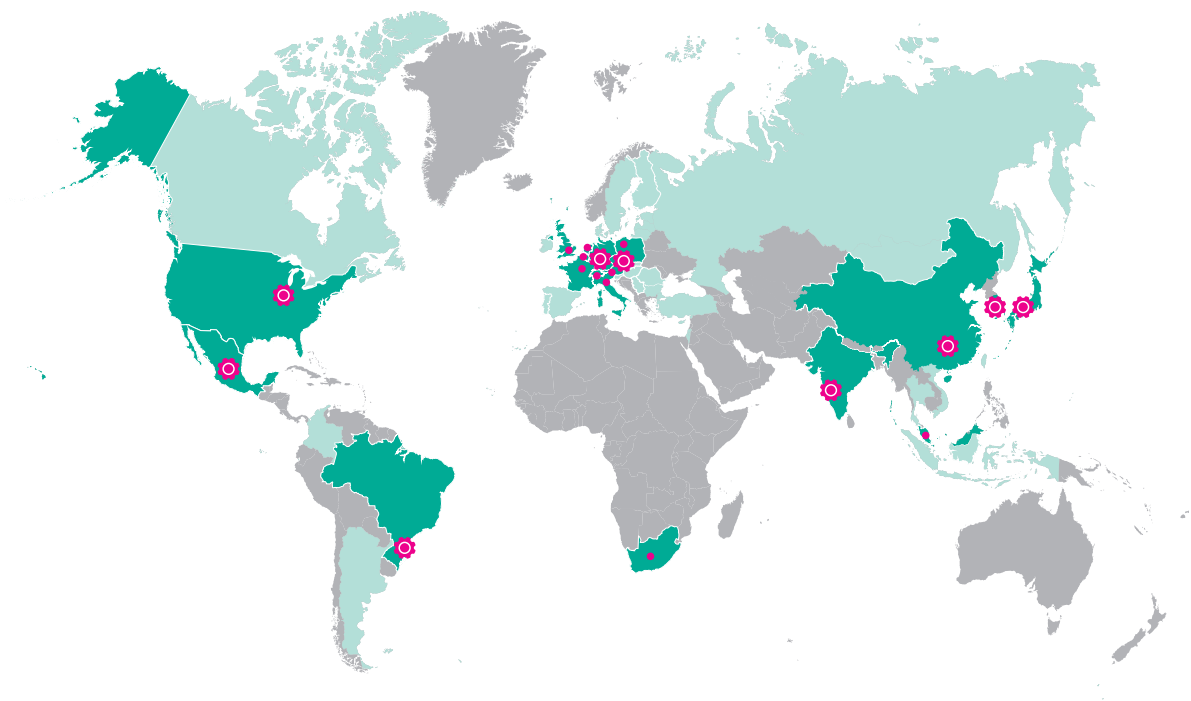

TOX®  PRESSOTECHNIK

TOX® PRESSOTECHNIK GmbH & Co. KG
Riedstrasse 4
88250 Weingarten / Germany

You can find your contact partner at:
tox-pressotechnik.com